

# Heliporter<sup>®</sup>

by  
Paravion<sup>®</sup> Technology, Inc.

## Owner's Manual

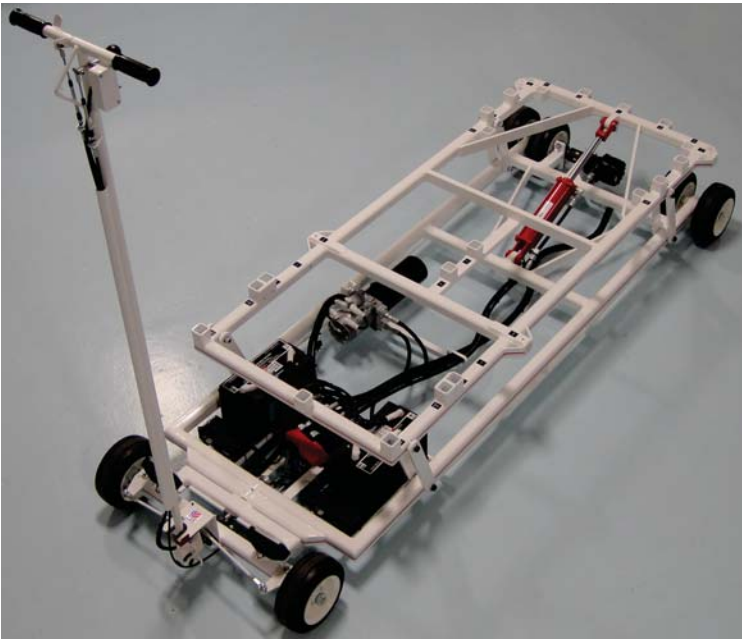

### 150 Series



## Introduction

**Congratulations**, you have purchased one of the finest helicopter ground handling vehicles on the market today. We at Paravion Technology, Inc. have strived to engineer the *Helicopter*<sup>®</sup> to be as maintenance free and simple to operate as possible. This vehicle will be a useful addition to your helicopter flight operation.

As with any new equipment, a necessary period of orientation should be observed. To maximize the use and safety of the *Helicopter*<sup>®</sup>, we recommend that the operator practice the operations without the aircraft aboard; then when proficiency is achieved, begin using with your aircraft in unconfined areas.



©Copyright 2012, Paravion Technology, Inc. Paravion<sup>®</sup> and Helicopter<sup>®</sup> are registered trademarks of Paravion Technology, Inc. Product specifications, prices, warranty and availability are subject to change without notice.



www.paravion.com  
E-mail: [paravion@paravion.com](mailto:paravion@paravion.com)

Phone: (970) 224-3898  
Fax: (970) 224-3899

# Table of Contents

<u>Description</u>	<u>Page</u>
H150E Assembly Instructions .....	3
H150TP Assembly Instructions .....	4
H150E Operation.....	5-6
H150TP Operation.....	7-8
Socket Schedule.....	9-10
H150E Battery Charger Operation .....	11-13
H150TP Battery Charger Operation .....	14-15
Service Instructions .....	16-17
Cold Weather Operation .....	18
APU Operation .....	18
Basic Replacement Parts .....	19
Warranty .....	20
Notes.....	21



www.paravion.com  
E-mail: [paravion@paravion.com](mailto:paravion@paravion.com)

Phone: (970) 224-3898  
Fax: (970) 224-3899

# HP150E Assembly Instructions

## Steering Handle Assembly

1. Remove tape from steering yoke.
2. Insert set screw into yoke.
3. Remove tape from the handle end.
4. Ensure key is still in handle end while inserting handle end into yoke.
5. Tighten set screw. Set screw should be recessed inside the yoke when tight.

## Batteries

1. Connect leads labeled “Pump Power” to Positive (+) terminal.
2. Connect “Jumper” between the two batteries as shown below.
3. Connect “Frame Ground” to Negative (-) terminal on second battery. Ensure all connections are tight.
4. If the APU option was included, this will also be operational by following the above steps.

### Batteries

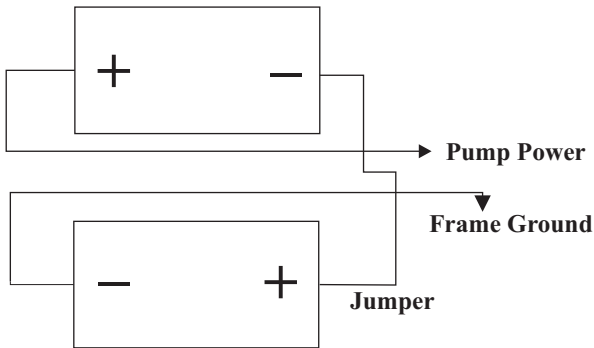

**Paravion<sup>®</sup>**  
**Technology Inc.**

www.paravion.com  
E-mail: paravion@paravion.com

Phone: (970) 224-3898  
Fax: (970) 224-3899

# HP150TP Assembly Instructions

## Steering Handle Assembly

1. Locate tongue to line up holes.
2. Insert bolt as provided.
3. Tighten as necessary to engage locking nut.

## Batteries

1. Connect leads labeled “Pump Power” to Positive (+) terminal.
2. Connect leads labeled “Frame Ground” to Negative (-) terminal.

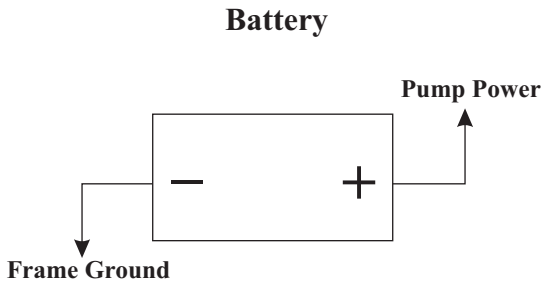

**Paravion<sup>®</sup>**  
**Technology Inc.**

www.paravion.com  
E-mail: [paravion@paravion.com](mailto:paravion@paravion.com)

Phone: (970) 224-3898  
Fax: (970) 224-3899

# Heliporter®

## H150E Operation

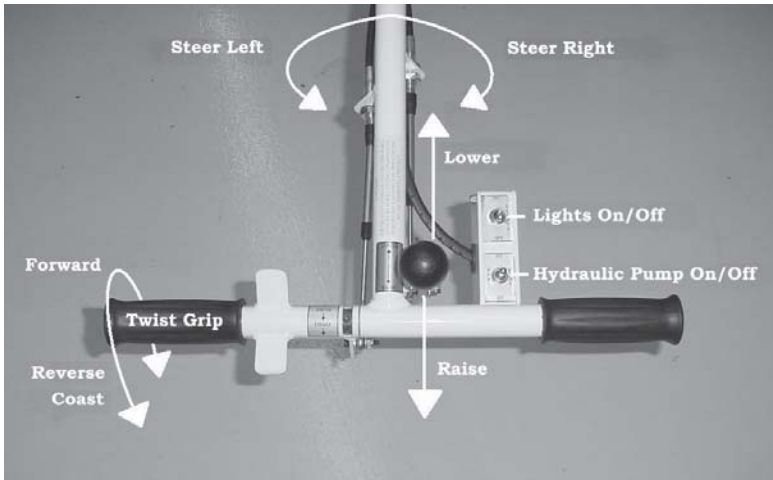

1. Rotate the twist grip (see Fig. 1) to aft stop. With additional pressure, force the grip past stop to the “Coast” detent position. This position allows the *Heliporter*® to freewheel and be maneuvered manually.

**Note:** Never attempt to position the *Heliporter*® under the aircraft by using the hydrostatic drive system.

2. Observe that the lifting platform is in a full “Down” position before maneuvering the *Heliporter*® under the aircraft.
3. Guide the *Heliporter*® between the skid gear by rotating the control handle assembly counter clockwise to turn left and clockwise to turn right (see Fig. 1). Maneuver the *Heliporter*® under the aircraft from front to rear.

**Caution:** Observe the aircraft belly area to avoid contacting antennas, lights, etc. with the *Heliporter*® while maneuvering under the helicopter.

4. Engage the hydraulic pump switch by pushing the toggle switch forward and holding it in the forward position.

**Note:** The toggle switch is preloaded toward the “Off” position, therefore the *Heliporter*® will stop automatically when pressure is released. Never operate the pump switch unless the Twist Grip and Raise & Lower Lever are in the neutral position.

**Paravion®**  
✓ **Technology** Inc.

www.paravion.com  
E-mail: paravion@paravion.com

Phone: (970) 224-3898  
Fax: (970) 224-3899

# Heliporter®

## H150E Operation

5. Raise the lifting platform slowly by pulling aft on the platform control until the *Heliporter*® lift pads make contact with the aircraft pickup points. Release the platform control stick and pump switch.
6. With proper alignment achieved and with the pump switch off, rotate the twist grip forward to the spring loaded “Neutral” position. This will engage the hydrostatic brakes and prevent the *Heliporter*® from moving as the helicopter's skids leave the ground. Re-engage the pump and continue to raise the platform.
7. When the desired height is achieved, release the platform control and hydraulic pump switch. With controls released, the aircraft will remain in the desired position.

**Caution:** The helicopter can be lowered by pushing forward on the platform control without the hydraulic pump operating. An abrupt forward movement of the platform control will cause rapid lowering of the helicopter, possibly causing damage to the aircraft or personnel. With the weight of the helicopter on the ground, it may be necessary to use the hydraulic pump to fully lower the platform.

8. The twist grip (see Fig. 1) controls forward and aft movement of the *Heliporter*®, it also controls the throttle speed. The speed is determined by the degree of rotation to the twist grip. A small rotation will move the *Heliporter*® slowly and full rotation will move the *Heliporter*® at full speed of 2.5 mph .

**Caution:** When engaging the hydrostatic drive, rotate the twist grip *slowly*.

9. To move a helicopter while being supported on the lifting platform, engage the hydraulic pump switch and rotate the left hand grip forward *slowly* to move rearward. To move forward, rotate the left handgrip *slowly* aft (See Fig. 1).
10. When the aircraft is raised and proper speed and direction are achieved, the operator can move the entire control handle assembly to the right or left of the aircraft to facilitate viewing the area toward which the aircraft is moving.

**CAUTION: Never take off or land over the *Heliporter*®.**

Paravion®  
✓Technology Inc.

www.paravion.com  
E-mail: paravion@paravion.com

Phone: (970) 224-3898  
Fax: (970) 224-3899



# Heliporter®

## H150TP Operation

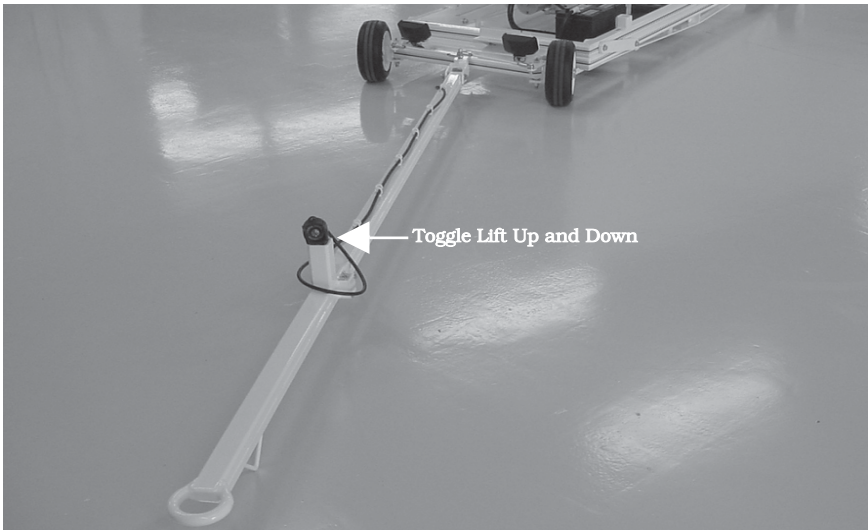

1. Observe that the lifting platform is in a full “Down” position before maneuvering the *Heliporter*® under the aircraft.
2. Guide the *Heliporter*® between the skid gear by moving the tongue assembly left and right. Maneuver the *Heliporter*® under the aircraft from front to rear.

**Caution:** Observe the aircraft belly area to avoid contacting antennas, lights, etc. with the *Heliporter*® while maneuvering under the helicopter.

3. Raise the lifting platform slowly by pushing the pump toggle switch until the *Heliporter*® lift pads make contact with the aircraft pickup points. Release the toggle switch.
4. With proper alignment achieved. Re-engage the toggle and continue to raise the platform.

**Paravion®**  
✓**Technology** Inc.

www.paravion.com  
E-mail: paravion@paravion.com

Phone: (970) 224-3898  
Fax: (970) 224-3899

# Heliporter®

## H150TP Operation

5. When the desired height is achieved, release the toggle switch. With the toggle switch released, the aircraft will remain in the desired position.
6. To move a helicopter while being supported on the lifting platform, attach the desired unit capable of moving the helicopter.

**Note:** Never leave the unit unattended while a helicopter is raised off the ground.

7. When the desired location of the aircraft is achieved, engage pump switch to lower platform. Continue to lower platform until it is in full down position.
8. *Heliporter*® is now ready to be removed from under the aircraft.

**CAUTION: Never take off or land over the *Heliporter*®.**

The logo for Paravion Technology Inc. features the word "Paravion" in a serif font with a registered trademark symbol, positioned above a horizontal line. Below the line, the word "Technology" is written in a similar serif font, with a checkmark symbol to its left. To the right of "Technology" is the word "Inc." in a smaller serif font.

www.paravion.com  
E-mail: [paravion@paravion.com](mailto:paravion@paravion.com)

Phone: (970) 224-3898  
Fax: (970) 224-3899

# HP 150 Socket Schedule

-1 SOCKET SCHEDULE	
A	206L, 407, F-480
B	206A/B, OH-58, 369
C	BELL 47
D	AS350 (OLD STYLE)
E	206A/B, F-28, F-480
F	OH-58
G	BELL 47
H	206L, 407, AS350 (OLD STYLE)
I	369
K	R44
L	R22
M	R22, R44
P	LIGHT FIXED WING

-2 SOCKET SCHEDULE	
A	206L, 407, F-480
B	206A/B, OH-58, 369
C	BELL 47
E	206A/B, F-28, F-480
F	OH-58
G	BELL 47
H	206L, 407, AS350 (OLD STYLE)
I	369
J	AS350
K	R44
L	R22
M	R22, R44
N	AS350
P	LIGHT FIXED WING

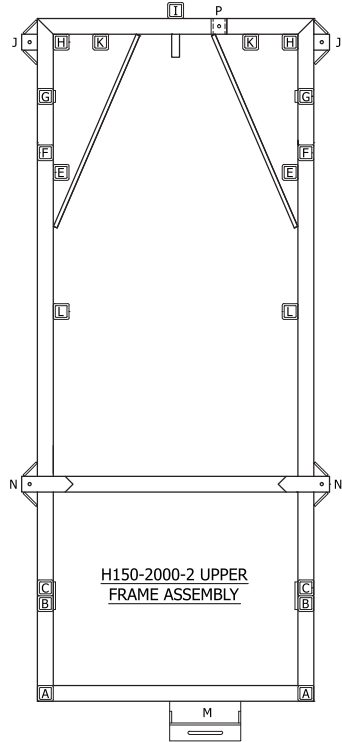
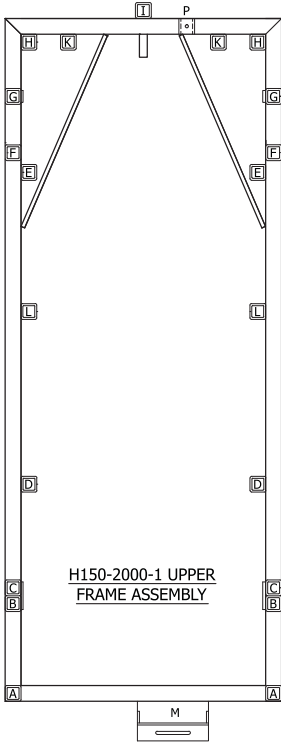

Paravion®  
Technology Inc.

www.paravion.com  
E-mail: paravion@paravion.com

Phone: (970) 224-3898  
Fax: (970) 224-3899

# HP 150 Socket Schedule

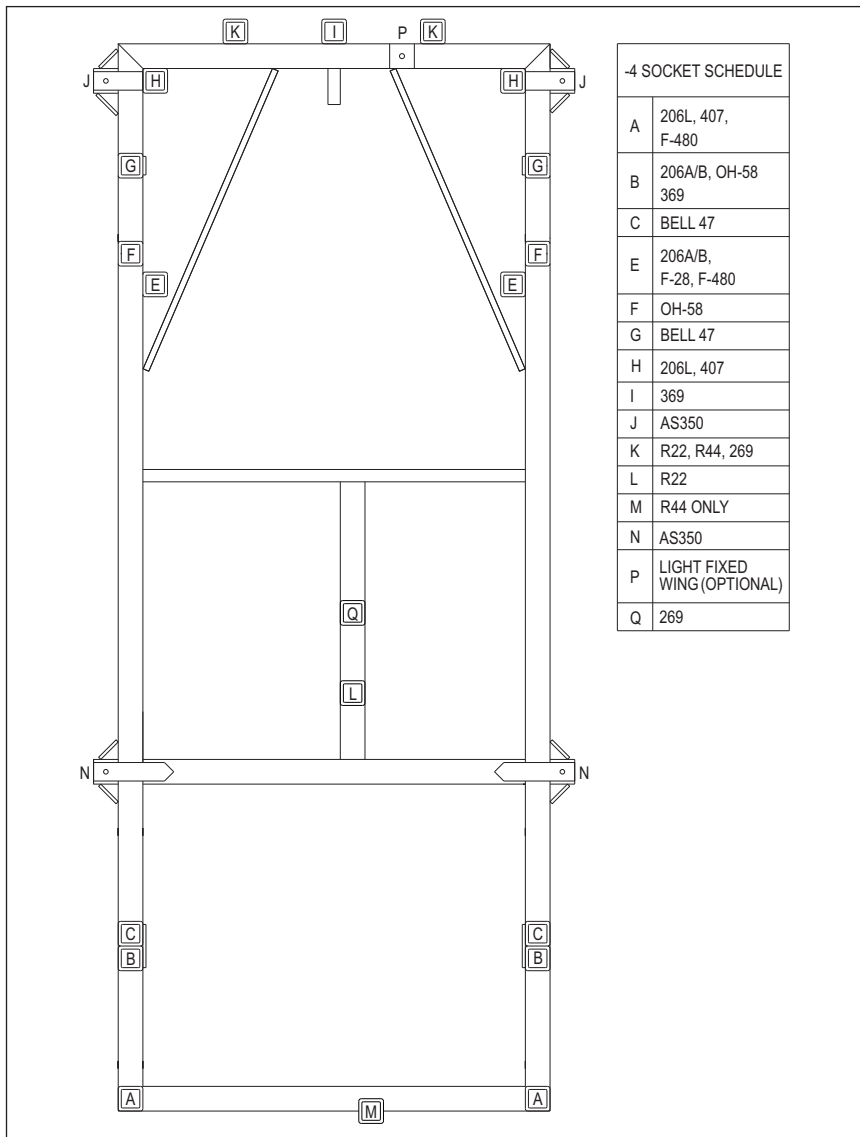

-4 SOCKET SCHEDULE	
A	206L, 407, F-480
B	206A/B, OH-58 369
C	BELL 47
E	206A/B, F-28, F-480
F	OH-58
G	BELL 47
H	206L, 407
I	369
J	AS350
K	R22, R44, 269
L	R22
M	R44 ONLY
N	AS350
P	LIGHT FIXED WING (OPTIONAL)
Q	269

**Paravion<sup>®</sup> Inc.**  
**Technology**

www.paravion.com  
 E-mail: paravion@paravion.com

Phone: (970) 224-3898  
 Fax: (970) 224-3899

# Heliporter®

## H150E Battery Charger Operation with HE50100-3 Charger



**HE50100-3:** This charger is fully automatic. It can be plugged in anytime the *Heliporter*® is not in use and will maintain the batteries as needed.

**LED Indicator information:**

**Red:** Power On

**Orange:** Charging

**Green:** Full Charge

**Flashing Green:** Battery Disconnect

**CAUTION:** Do not operate *Heliporter*® while charger is plugged in.

**CAUTION:** Make sure to set the Voltage Selector Switch (Flat Red) on the back of the charger to the proper voltage for your area.

**Paravion®  
✓Technology Inc.**

www.paravion.com  
E-mail: [paravion@paravion.com](mailto:paravion@paravion.com)

Phone: (970) 224-3898  
Fax: (970) 224-3899

# Heliporter®

## H150E Battery Charger Operation with HE50100-2 Charger



1. **Charging a Battery** - This charger is equipped with Auto On-Off technology which senses when a battery has reached full charge and then decreases the charge level to a trickle.

**Note:** Charger will continue to “hum” as it monitors the battery charge level.

2. **Select Function** - Select “5A, 24V”.

**Note:** “E” Models are 24V.



**Note:** Pre-activation of a low or dead battery may be required.

**Manual:** Select **MANUAL** and charge for 5-15 minutes then select the desired charge rate to continue charging. Repeat if the battery does not start taking a charge.

**Auto:** Select **AUTO** if you will be charging a battery.



**CAUTION:** Do not operate *Heliporter*® while charger is plugged in.

**Paravion®**  
✓ **Technology** Inc.

www.paravion.com  
E-mail: paravion@paravion.com

Phone: (970) 224-3898  
Fax: (970) 224-3899

# Heliporter®

## H150E Battery Charger Operation with HE50100-4 Charger

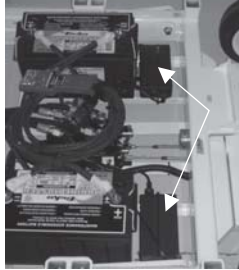

**HE50100-4:** This charger is fully automatic. It can be plugged in anytime the *Heliporter*® is not in use and will maintain the batteries as needed.

**LED Indicator information:**

**Orange:** Charging

**Green:** Full Charge

**Flashing Green:** Output Not Connected

**CAUTION:** Do not operate *Heliporter*® while charger is plugged in.

**CAUTION:** Make sure to set the Voltage Selector Switch (Flat Red) on the back of the charger to the proper voltage for your area.

**Paravion®**  
✓**Technology** Inc.

www.paravion.com  
E-mail: [paravion@paravion.com](mailto:paravion@paravion.com)

Phone: (970) 224-3898  
Fax: (970) 224-3899

# Heliporter®

## H150TP Battery Charger Operation with HE50100-2 Charger



1. **Charging a Battery** - This charger is equipped with Auto On-Off technology which senses when a battery has reached full charge and then decreases the charge level to a trickle.

**Note:** Charger will continue to “hum” as it monitors the battery charge level.

2. **Select Function** - Select “10A, 12V”.

**Note:** “TP” Models are 12V.



**Note:** Pre-activation of a low or dead battery may be required.

**Manual:** Select **MANUAL** and charge for 5-15 minutes then select the desired charge rate to continue charging. Repeat if the battery does not start taking a charge.

**Auto:** Select **AUTO** if you will be charging a battery.



**CAUTION:** Do not operate *Heliporter*® while charger is plugged in.

**Paravion®**  
✓ **Technology** Inc.

www.paravion.com  
E-mail: paravion@paravion.com

Phone: (970) 224-3898  
Fax: (970) 224-3899



# Heliporter®

## H150TP Battery Charger Operation with HE50100-4 Charger



**HE50100-4:** This charger is fully automatic. It can be plugged in anytime the *Heliporter*® is not in use and will maintain the batteries as needed.

**LED Indicator information:**

**Orange:** Charging

**Green:** Full Charge

**Flashing Green:** Output Not Connected

**CAUTION:** Do not operate *Heliporter*® while charger is plugged in.

**CAUTION:** Make sure to set the Voltage Selector Switch (Flat Red) on the back of the charger to the proper voltage for your area.

**Paravion®  
✓Technology Inc.**

www.paravion.com  
E-mail: [paravion@paravion.com](mailto:paravion@paravion.com)

Phone: (970) 224-3898  
Fax: (970) 224-3899

# Heliporter®

## Servicing Instructions

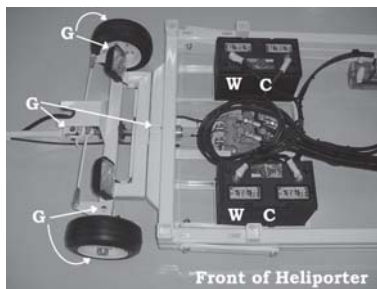

**Fig. 2**

- W - Service batteries with water
- G - Grease indicated locations
- C - Charge batteries using provided charger

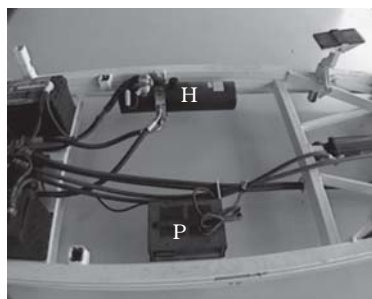

**Fig. 3**

- H - Service hydraulic system with 10W30 motor oil
- P - Connect to AC electrical outlet to charge batteries

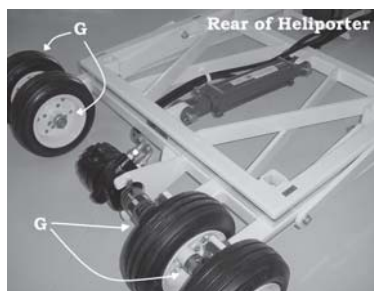

**Fig. 4**

**Paravion®  
Technology Inc.**

www.paravion.com  
E-mail: paravion@paravion.com

Phone: (970) 224-3898  
Fax: (970) 224-3899

# Heliporter®

## Service Instructions

### Recommended Lubricants and Service Terms

<b>Grease:</b>	Quality lithium based automotive-type grease
<b>Battery Fluids:</b>	Distilled water
<b>Hydraulic Fluid:</b>	10W30 Motor Oil
<b>Service Points:</b>	(See Figs. 2, 3, and 4)

1. Check the battery fluid levels monthly. Fill to proper levels if low. (Fig. 2).
2. Check the hydraulic fluid level monthly. Fill to 1/2 of reservoir capacity with the platform in full “down” position. (Fig. 3)
3. If stored outdoors, cover the charging system with a waterproof cover when not in use. (Fig. 3)

**Caution:** Never operate the charger while covered.

4. If using pneumatic tires, maintain tire pressure to the tire manufacturer's recommendation.
5. Inspect tires, hoses, couplings, cables, and electrical wires for serviceable condition before each use.
6. Plug the charging system into AC electric receptacle for system recharging as necessary. (Fig. 3)
7. Check all hardware at attachment points for security before each use.
8. Grease all zerks, a minimum of twice yearly. The wheel bearings should be greased more often, as usage and environmental conditions dictate. (Fig. 2 & 4).
9. Replace the protective pads at lift contact points as necessary.

 Paravion®  
Technology Inc.

www.paravion.com  
E-mail: paravion@paravion.com

Phone: (970) 224-3898  
Fax: (970) 224-3899

# Heliporter®

## Cold Weather Operation

*Heliporter*® hydraulic systems are serviced with 10W30 Motor Oil.

In extreme cold weather environments, the operator may choose to utilize a standard brand hydraulic fluid to improve performance of the *Heliporter*® when cold weather may be affecting the viscosity of the motor oil. If the operator desires this choice, perform the following:

1. Completely drain and flush the hydraulic system of oil.
2. Refill the hydraulic reservoir approximately half-full with hydraulic fluid.
3. Follow the Service Instructions as published.

## HP150E APU Operation

The optional APU is available in 24 VDC. Prior to its use, check for proper voltage. To operate the APU, simply plug the connector into the aircraft receptacle.

 Paravion®  
✓Technology Inc.

www.paravion.com  
E-mail: [paravion@paravion.com](mailto:paravion@paravion.com)

Phone: (970) 224-3898  
Fax: (970) 224-3899

# Heliporter<sup>®</sup>

## HP150E Basic Replacement Parts

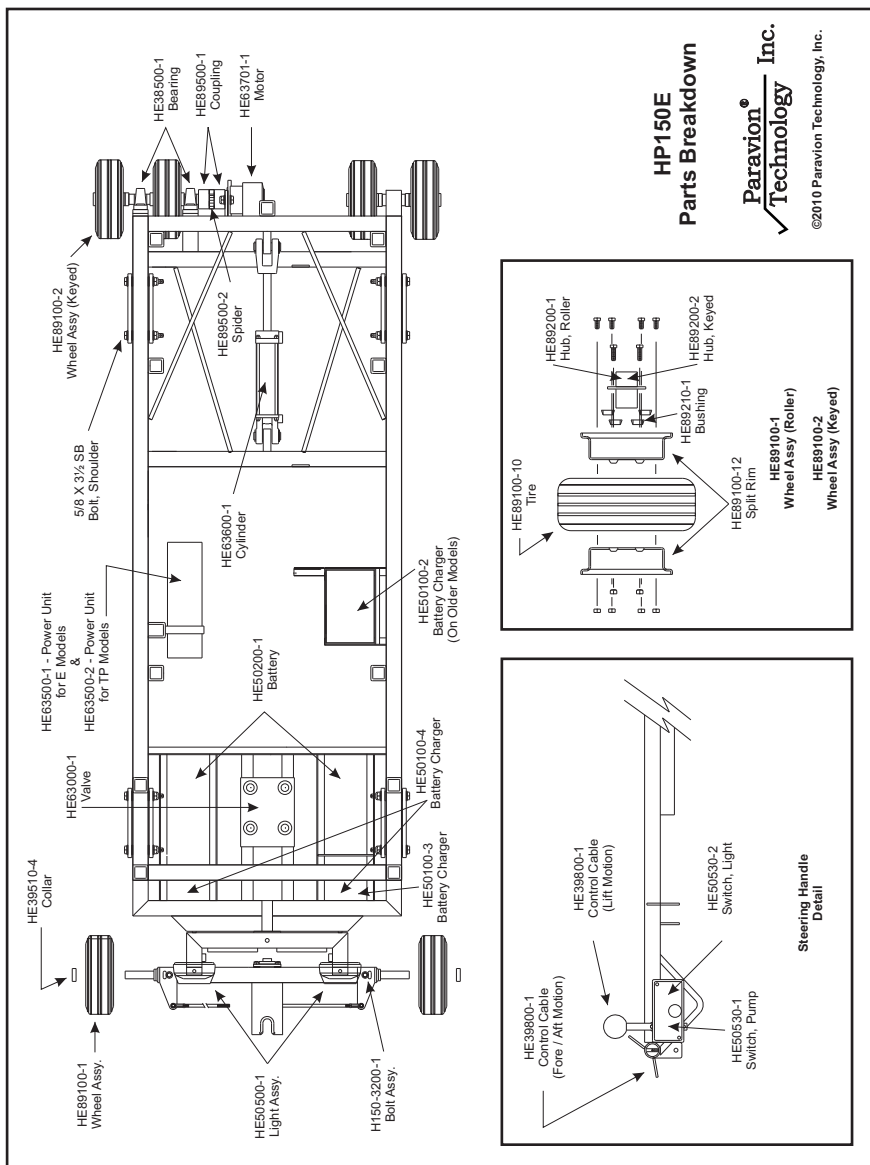

**Paravion<sup>®</sup> Technology Inc.**

www.paravion.com  
E-mail: paravion@paravion.com

Phone: (970) 224-3898  
Fax: (970) 224-3899

# WARRANTY

**Warranty Terms:** Paravion® Technology, Inc. warrants that the components contained in this product shall be free from defects in materials and workmanship under normal use and service for 1 year from the date of purchase, if and only if the product is maintained and operated in accordance with the specifications and instructions provided by Paravion® Technology, Inc.

**Limitations and Exclusions:** This warranty shall not apply to any product repaired or altered by parties other than Paravion® Technology, Inc. unless express prior authorization is granted; nor shall this warranty apply to any product subjected to misuse or accident unless proof is submitted to the satisfaction of Paravion® Technology, Inc. that such misuse or accident was not a cause for the claimed defect.

The sole responsibility and liability of Paravion® Technology, Inc. and your exclusive remedy under any claim arising out of, connected with, or resulting from this sale or the performance or breach of any condition of warranty thereunder, or from the manufacture, delivery, or use of the product shall be the repair or replacement of the defective parts.

In no event, whether as a result of a breach of contract, warranty, tort (including negligence) or otherwise, shall Paravion® Technology, Inc. be liable for any special, consequential, incidental or penal damages or expenses including but not limited to loss of profit, goodwill, or revenues, loss of associated equipment, cost of capital, cost of substitute products, facilities or services, down time, or costs or claims of third parties for such damages or expense.

*The foregoing warranty is exclusive and in lieu of all other warranties or remedies whether written, oral, implied or statutory. Any and all implied warranties or merchantability, fitness for a particular purpose, course of dealing, or usage of trade are hereby disclaimed and excluded.*

Acceptance of this product by you shall constitute your acknowledgement and acceptance of the terms, provisions, limitations, and exclusions set forth herein. Such terms, provisions, limitations, and exclusions shall not be modified, deleted, or supplemented except by the express written acknowledgement of Paravion® Technology, Inc. Warranty is non-transferable and subject to change without notice

**Warranty Performance:** All claims under this warranty shall be made to Paravion® Technology, Inc. All returned parts must be shipped prepaid for evaluation to Paravion® Technology, Inc. Full details of the symptoms of the malfunction should be included to assist in this evaluation. Warranty credit or replacement will be extended only after Paravion® Technology, Inc. has determined that all conditions of this warranty have been met.

**Paravion®  
Technology** Inc.

www.paravion.com  
E-mail: [paravion@paravion.com](mailto:paravion@paravion.com)

Phone: (970) 224-3898  
Fax: (970) 224-3899

# NOTES

 Paravion<sup>®</sup>  
Technology Inc.

[www.paravion.com](http://www.paravion.com)  
E-mail: [paravion@paravion.com](mailto:paravion@paravion.com)

Phone: (970) 224-3898  
Fax: (970) 224-3899

Paravion®  
✓ Technology Inc.  
2001 Airway Avenue  
Fort Collins, CO 80524  
USA

[www.paravion.com](http://www.paravion.com)  
E-mail: [paravion@paravion.com](mailto:paravion@paravion.com)

Phone: (970) 224-3898  
Fax: (970) 224-3899